

United States of America  
Department of Transportation—Federal Aviation Administration  
**Supplemental Type Certificate**

*Number* SA2150NM

*This certificate, issued to*

**Rosen Sunvisor Systems  
86365 College View Road  
Eugene, OR 97405**

*certifies that the change in the type design for the following product with the limitations and conditions therefor as specified hereon meets the airworthiness requirements of Part \* of the \* Regulations.*

*Original Product—Type Certificate Number:*

\*See attached Approved Model List (AML)

*Make:*

No. SA2150NM for a list of approved airplane.

*Model:*

models and applicable airworthiness regulations

*Description of the Type Design Change:* Cockpit Sun Visor installation in accordance with FAA approved ROSEN Drawing List Number R500S-00DL, dated August 29, 1983, or later FAA approved revisions.

*Limitations and Conditions:* Approval of this change in type design applies to only those Cessna Aircraft Models listed on AML No. SA2150NM, dated March 24, 2003, or later FAA approved revisions. This approval should not be extended to other aircraft of this model on which other previously approved modifications are incorporated unless it is determined that the relationship between this change and any other previously approved modifications, including changes in type design, will introduce no adverse effect upon the airworthiness of that aircraft. A copy of this Certificate and FAA approved ROSEN Drawing List Number R500S-00DL, shall be maintained as part of the permanent records for the modified aircraft.

If the holder agrees to permit another person to use this certificate to alter the product, the holder shall give the other person written evidence of that permission.

*This certificate and the supporting data which is the basis for approval shall remain in effect until surrendered, suspended, revoked, or a termination date is otherwise established by the Administrator of the Federal Aviation Administration.*

*Date of application:* August 29, 1983

*Date reissued:* March 24, 2003

*Date of issuance:* September 30, 1983

*Date amended:* 5/3/83; 12/18/91; 12/29/93; 9/5/02;  
3/24/03



*By direction of the Administrator*

*[Handwritten Signature]*  
(Signature)

Acting Manager, Seattle Aircraft  
Certification Office

(Title)

Any alteration of this certificate is punishable by a fine of not exceeding \$1,000, or imprisonment not exceeding 3 years, or both.

This certificate may be transferred in accordance with FAR 21.47.

**FAA APPROVED MODEL LIST (AML) SA2150NM  
FOR  
INSTALLATION OF ROSEN SUNVISOR SYSTEMS COCKPIT SUN VISOR**

ISSUE DATE: December 27, 1993

ITEM	AIRPLANE MAKE	AIRPLANE MODEL	TYPE CERTIFICATE NUMBER	CERTIFICATION BASIS FOR ALTERATION	FAA APPROVED DRAWING LIST		AML AMENDED DATE
					NUMBER	REVISION NO. AND DATE	
1.	Cessna	500, 550, S550, 552, 560	A22CE	14 CFR 25	R500S-00DL	8/29/83	7/20/09
2.	Cessna	525, 525A, 525B	A1WI	14 CFR 23	R500S-00DL	8/29/83	3/28/06

FAA APPROVED:



Manager, Seattle Aircraft  
Certification Office

REISSUED: March 28, 2006

AMENDED: Sept. 12, 2002; March 24, 2003, March 28, 2006,  
July 22, 2009

Department of Transportation Federal Aviation Administration

# Supplemental Type Certificate

Number SA2151NM

This certificate, issued to **Rosen Sunvisor Systems, LLC**  
**86365 College View Road**  
**Eugene, OR 97405**

certifies that the change in the type design for the following product with the limitations and conditions therefor as specified hereon meets the airworthiness requirements of Part 23 of the Federal Aviation Regulations. (See Type Certificate Data Sheet A27CE for complete certification basis.)

Original Product—Type Certificate Number: A27CE  
 Make: Cessna  
 Model: 501, 551

Description of the Type Design Change: Cockpit Sun Visor installation in accordance with FAA approved Rosen Drawing List No. R500S-00DL, dated August 29, 1983, or later FAA approved revision.

Limitations and Conditions: The approval of this change in type design applies basically to the above model aircraft only. This approval should not be extended to aircraft of this model on which other previously approved modifications are incorporated unless it is determined that the interrelationship between this change and any of those other previously approved modifications, including changes in type design, will introduce no adverse effect upon the airworthiness of the aircraft. A copy of this Certificate and FAA approved Drawing List Number R500S-00DL shall be maintained as part of the permanent records of the modified aircraft.

If the holder agrees to permit another person to use this certificate to alter the product, the holder shall give the other person written evidence of that permission.

This certificate and the supporting data which is the basis for approval shall remain in effect until surrendered, suspended, revoked, or a termination date is otherwise established by the Administrator of the Federal Aviation Administration.

Date of application: August 29, 1983                      Date reissued: March 24, 2003  
 Date of issuance: September 30, 1983                      Date amended: March 24, 2003



By direction of the Administrator  
*[Signature]*  
 (Signature)  
 Acting Manager, Seattle Aircraft Certification Office  
 (Title)

Any alteration of this certificate is punishable by a fine of not exceeding \$1,000, or imprisonment not exceeding 3 years, or both.  
 This certificate may be transferred in accordance with FAR 21.47.



Transport  
Canada

Transports  
Canada

Aircraft Certification  
800-1601 Airport Road N. E.  
Calgary, AB.  
T2E 6Z8 Canada

Your file      Votre référence

Our file      Notre référence  
C-10-1021  
C-10-1022

Rosen Sunvisor Systems  
86365 College View Road  
Eugene, OR 97405  
United States of America

December 1, 2010

**Attn:** Gary Hanson  
**Subject:** Transport Canada Acceptance of FAA STC SA2150NM and SA2151NM  
**Reference:** FAA Application Letter, Dated November 22, 2010

This is in response to the subject application letter requesting Transport Canada approval of the subject STC.

In accordance with our current policy associated with the review of foreign STCs, some STCs applicable to certain categories of aircraft may be accepted solely on the basis of their foreign certification, and do not require the issue of a corresponding certificate by Transport Canada. The subject STC falls within these criteria.

This STC will be entered in the national index of STCs that have been reviewed and accepted by Transport Canada for installation on Canadian-registered aeronautical products.

This letter confirms formal acceptance of STC SA2150NM and SA2151NM by Transport Canada.

Regards,

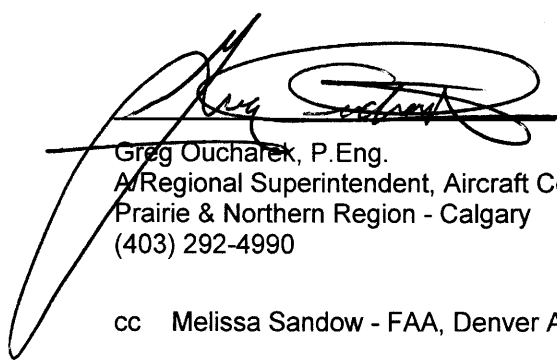

Greg Oucharek, P.Eng.  
Regional Superintendent, Aircraft Certification  
Prairie & Northern Region - Calgary  
(403) 292-4990

cc Melissa Sandow - FAA, Denver ACO

RECD DEC 06 2010

Canada



**SUPPLEMENTAL TYPE CERTIFICATE**  
**10045675**

This Supplemental Type Certificate is issued by EASA, acting in accordance with Regulation (EC) No. 216/2008 on behalf of the European Community, its Member States and of the European third countries that participate in the activities of EASA under Article 66 of that Regulation and in accordance with Commission Regulation (EU) No. 748/2012 to

**ROSEN SUNVISOR SYSTEMS L.L.C.**

**86365 COLLEGE VIEW ROAD  
EUGENE OR 97405  
USA**

and certifies that the change in the type design for the product listed below with the limitations and conditions specified meets the applicable Type Certification Basis and environmental protection requirements when operated within the conditions and limitations specified below:

**Original Type Certificate Number : EASA.IM.A.207**  
**Type Certificate Holder : CESSNA AIRCRAFT COMPANY**  
**Type Design - Model : CESSNA 500, 550, S550, 560**  
**Original STC Number : FAA STC SA2150NM**

**Description of Design Change:**  
Rosen Sunvisor System  
Monorail mounted cockpit sunvisor

**EASA Certification Basis:**  
The Certification Basis (CB) for the original product remains applicable to this certificate/ approval.  
The requirements for environmental protection and the associated certified noise and/ or emissions levels of the original product are unchanged and remain applicable to this certificate/ approval.

See Continuation Sheet(s)

  
**Alexandre PEYTOURAUX**  
**Project Certification Manager**  
**Large Aeroplanes**

**For the European Aviation Safety Agency,**

**Date of issue: 11 July 2013**

Note:  
The following numbers are listed on the certificate:  
EASA current Project Number: 0010022622-001

SUPPLEMENTAL TYPE CERTIFICATE - 10045675 - ROSEN SUNVISOR SYSTEMS L.L.C.

TE.STC.00091-003 - Copyright European Aviation Safety Agency. All rights reserved.



**Associated Technical Documentation:**

Rosen Sunvisor Systems, Drawing List R500S-00DL, revision G, dated 22 January 2009  
Rosen Sunvisor Systems, Installation Instructions for Cessna Citation Monorail Sunvisor System Kit R500S-010-1, Doc. 9041-0126-001, rev D, date 21 January 2009.  
Rosen Sunvisor Systems, Installation Instructions for Cessna Citation Monorail Sunvisor System Kit R500S-010-2, Doc. 9041-0126-002, rev D, date 21 January 2009  
or later revisions of the above listed documents approved by EASA in accordance with EASA ED Decision 2004/04/CF (or subsequent revisions of this decision) and/ or the Technical Implementation Procedures of EU/ USA Bilateral Agreement.

**Limitations/Conditions:**

None

- end -

**Note:**

The following numbers are listed on the certificate:  
EASA current Project Number: 0010022622-001

SUPPLEMENTAL TYPE CERTIFICATE - 10045675 - ROSEN SUNVISOR SYSTEMS L.L.C.

TE.STC.00091-003 - Copyright European Aviation Safety Agency. All rights reserved.

## SUPPLEMENTAL TYPE CERTIFICATE

**10059941**

This Supplemental Type Certificate is issued by EASA, acting in accordance with Regulation (EC) No. 216/2008 on behalf of the European Community, its Member States and of the European third countries that participate in the activities of EASA under Article 66 of that Regulation and in accordance with Commission Regulation (EU) No. 748/2012 to:

### **ROSEN SUNVISOR SYSTEMS L.L.C.**

**86365 COLLEGE VIEW ROAD  
EUGENE OR 97405  
USA**

and certifies that the change in the type design for the product listed below with the limitations and conditions specified meets the applicable Type Certification Basis and environmental protection requirements when operated within the conditions and limitations specified below:

**Original Type Certificate Number:** US A27CE

**Type Certificate Holder:** TEXTRON AVIATION INC.

**Type:** 501, 551

**Model:** 501 (Citation I)

551 (Citation II)

**Original STC Number:** FAA STC SA2151NM

**Description of Design Change:**

Rosen Sunvisor System – monorail mounted cockpit sunvisor

**EASA Certification Basis:**

The Certification Basis (CB) for the original product remains applicable to this certificate/ approval. The requirements for environmental protection and the associated certified noise and/ or emissions levels of the original product are unchanged and remain applicable to this certificate/ approval.

See Continuation Sheet(s)

**For the European Aviation Safety Agency**

**Date of Issue:** 03 November 2016



**Dominique ROLAND**

**Head of General Aviation and  
Remotely Piloted Aircraft Systems (RPAS)**

10022621

SUPPLEMENTAL TYPE CERTIFICATE - 10059941 - ROSEN SUNVISOR SYSTEMS L.L.C. - 303362

**Associated Technical Documentation:**

Cockpit Sunvisor installation iaw. FAA approved Rosen Drawing List No. R500S-00DL or later revisions of the above listed documents approved by EASA in accordance with EASA ED Decision 2004/04/CF (or subsequent revisions of this decision) and/ or the Technical Implementation Procedures of EU/ USA Bilateral Agreement.

**Limitations/Conditions:**

Prior to installation of this design change it must be determined that the interrelationship between this design change and any other previously installed design change and/ or repair will introduce no adverse effect upon the airworthiness of the product.

- End -





**Monorail Sunvisor System**  
**for Cessna Citation**

Date	Revision	Approved
2/17/22	P	SYS

Drawing List  
**R500S-00DL**

Doc #:9040-0126-001

R500S-010		PART NUMBER	Replacement for	DESCRIPTION	REV
-1	-2				
◆		<b>1260000-1</b>	<b>R500S-010-1, R1260000-1</b>	<b>Citation I/II Sunvisor System</b> (SN213 and up)	<b>E</b>
	◆	<b>1260000-2</b>	<b>R500S-010-2, R1260000-2</b>	<b>Citation I/II Mod Sunvisor System</b> (SN <213)	<b>E</b>
1		1260100-1	R500S-200-3, R1260100-1	Citation I/II Rail Assembly	E
	1	1260100-2	R500S-200-MOD, R1260100-2	Citation I/II Mod Rail Assembly	E
	1	R1260108	R500-100-DCN-1-2A	Side Bracket Pilot Side (MOD)	C
	1	R1260109	R500-100-DCN-1-3A	Side Bracket Copilot Side (MOD)	C
1	1	1260101	R500S-100-1	Monorail	B
1		R1260102	R500S-100-2	Side Bracket Pilot Side	C
1		R1260103	R500S-100-3	Side Bracket Copilot Side	D
1	1	1260104	R500S-100-4	Front Bracket	C
2	2	1260105	R500S-100-5	End Bracket	C
	2	1260106	R500S-100-11	Citation Barrel Nut	C
	1	1260110	R500S-100-12	Front Mod Plate	C
<b>2</b>	<b>2</b>	<b>1260200</b>	<b>R1260200, R500S-101-B</b>	<b>Visor Assembly</b>	<b>E</b>
2	2	1260210	R500S-101-CBB; R1260210	Clamping Block / Nut Plate Assy	D
2	2	1120000-001		Clamping Block Complete Assembly	K
2	2	1120101-001	RCBS-100-7A, R1120101-001	Nut Plate, Standard	L
2	2	1120102-001	RCBS-100-8AB, R1120102-002	Clamping Block Body	L
2	2	1120104		Thumb Knob, Standard	M
2	2	1120203	R1120203, RCBS-300-8	Swivel, Clamping Block	P
2	2	1260202		Swivel Nut Plate, Citation Monorail System	D
2	2	1260401	R500S-101-3AA, R1260401	Lens	E
2	2	1260402	R500S-101-1B	Lens, Green (Optional replacement only)	D
Continued...					

# Rosen®

SUNVISOR SYSTEMS

			KIT		
		<b>RCBS-300-11M</b>		<b>Kit, Standard Thumb Knob</b>	D
		1120104-002		Thumb Knob	M
		RCBS-300-18		Spring	
		PCS-1000-14-STZO		E-Clip	
		<b>RCBS-100</b>		<b>Clamping Block Assembly</b>	E
		1120000-001		Complete Assembly	K
		1110202		Plate, Swivel Nut	E
		832X716FSHCSSB		8-32 x 7/16 FSHC B/P Screw	
		832X1/4BSHCSSB		8-32 x 1/4 BSHC B/P Screw	
		<b>R1260401</b>		<b>Lens Kit</b>	E
		<b>R1260402</b>		<b>Lens, Green, Kit</b>	D
1		9041-0126-001		Installation Instructions for Cessna Citation	D
	1	9041-0126-002		Install Instructions for Cessna Citation 'Mod'	D



# Installation Instructions for Cessna Citation (Kit R500S-010-2) 'Mod' Monorail Sunvisor System (Citation S/N 1-10, 12-213)

p/n R1260000-2

This is an FAA STC'd installation requiring a log book entry upon completion.

Doc: 9041-0126-002

Rev	Date	Approved
D	1/21/09	GH

Please read through these instructions completely before beginning.

## Hardware:

- |   |                |                                  |
|---|----------------|----------------------------------|
| 1 | 3/32 Hex Key   |                                  |
| 1 | 7/64 Hex Key   |                                  |
| 2 | PS10F16CPG02NA | #10-32x1 Nylon Washer SS Screw   |
| 6 | PS8C16CPG02NA  | #8-32x1 Nylon Washer SS Screw    |
| 2 | PS8C5CPG02NA   | #8-32x5/16 Nylon Washer SS Screw |
| 1 | 1260110        | Mod Plate                        |
| 2 | 1260106        | Barrel Nut                       |

- Remove existing automotive style sun visors including pivot arms and front and rear plastic retainer clips.
- Remove Royalite shroud which is directly behind the center plastic bracket.
- Remove backing block that is glued to the rear of Royalite (the backing block may already be loose due to age).
- Place front mod plate with threaded holes up in the location originally taken by the backing block in the rear of the Royalite shroud. Align through holes in mod plate and holes in Royalite, then mark the threaded hole location. Drill two 3/16 inch holes in the shroud for fastener clearance at the marked locations.
- Align and attach the mod plate to the shroud temporarily using 2 #8-32x5/16" Nylon Washer Screws.
- Reattach shroud and mod plate assembly to the center post using 2 #8-32x1" screws. Re-install and tighten trim screws.
- Remove the #8-32x5/16 screws holding the mod plate to the shroud for later use.
- Install the side barrel nuts (P/N 1260106) into the clevises originally occupied by the visor pivot arms. It may be a good idea to have a #10-32x1 mounting screw in the barrel nut to help with the installation. After the barrel nut is in the clevis tighten the clevis set screw just enough to hold the nut in place. Remove the #10-32x1 screw.
- Using the #8-32x5/16 screws provided, loosely fasten the front bracket in place.
- Using the #10-32x1 screws provided, loosely fasten both forward side brackets, using the middle slotted hole for the fastener.
- For each rear attachment, use the forward nut plate and secure with one #8-32x1 screw. Use the other #8-32x1 screw as filler for the aft hole.

- With all the attachment points completed, tighten the side barrel nuts in the old visor clevis and then tighten the side brackets in place. The side bracket should pull in to conform to the shape of the trim material.
- Tighten both front and rear screws.
- To install the visor assemblies onto the rail, loosen the thumb knob until the clamp just fits over the rail, then install with the knob towards the pilot's position.
- Tighten the knob to just snug, rotate the visor to overhead, and install the 'E-clip' onto the groove on the threaded end of the thumb knob.

NOTE: The 'E-clip' is installed to prevent over loosening of the thumb knob.

- When the visor is on the rail the tensioning knob should face AFT.
- To move the visors, loosen the thumb tensioning knob until the clamp is loose enough to be slid along the monorail while holding the thumb knob. In order to move past the mounting brackets the visor must be positioned so that the clamps pass over the brackets.
- Your monorail system is equipped with a swivel design that allows rotation about the axis of the lens. Rotational tension can be adjusted by adjusting one or both of the hex socket head cap screws on the back side of the clamp block and below the thumb knob screw.
- The visor should be aligned parallel with the clamp block before sliding along the monorail.
- As this is a one piece monorail system, either visor can move the entire length of the rail, allowing complete sun shielding not previously available.

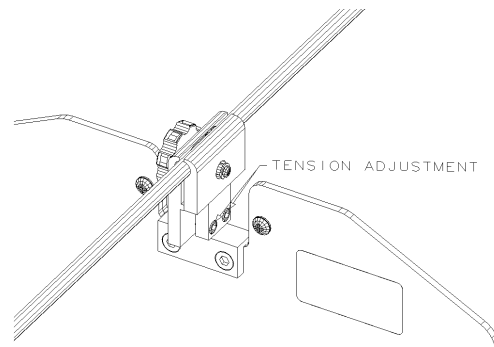

### **Continued Airworthiness Instructions:**

- **(On the ground only)**
  - Periodically clean the lenses with a soft cloth and Rosen Plastic Cleaner, Polisher and Protectant, or mild soap and water. Do not use abrasives on the lens.
  - Periodically adjust the pivot tensions on the visor assemblies.
  - Periodically clean rail with a non-residue alcohol based cleaner.
  - Periodically remove and clean the clamp features on the visor clamp block using an alcohol based solution.
- Updates to this continued airworthiness section are available on the Rosen Website. ([www.rosenvisor.com](http://www.rosenvisor.com))

The most up to date version of this document is available on the Rosen Website. ([www.rosenvisor.com](http://www.rosenvisor.com)) We recommend that you periodically look to make sure you are using the most current version.

### **Airworthiness Limitations:**

The Airworthiness Limitations Section is FAA approved and specifies maintenance required under §43.16 and §91.403 of the Federal Aviation Regulations unless an alternative program has been FAA approved.

There are no airworthiness limitations associated with this installation.