

Department of Transportation Federal Aviation Administration

# Supplemental Type Certificate

Number SA3342NM

This certificate, issued to **Rosen Sunvisor Systems**  
**86365 College View Road**  
**Eugene, OR 97405**

certifies that the change in the type design for the following product with the limitations and conditions therefor as specified hereon meets the airworthiness requirements of Part 3 of the Civil Air Regulations.

Original Product—Type Certificate Number: A5CE  
Make: Gates Learjet Inc.  
Model: 23

Description of the Type Design Change: Cockpit Sun Visor installation in accordance with FAA approved Rosen Drawing List Number RL-00DL, Revision A, dated March 18, 1986, or later FAA approved revision.

Limitations and Conditions: The approval of this change in type design applies basically to the above model aircraft only. This approval should not be extended to aircraft of this model on which other previously approved modifications are incorporated unless it is determined that the interrelationship between this change and any of those other previously approved modifications, including changes in type design, will introduce no adverse effect upon the airworthiness of the aircraft. A copy of this Certificate and FAA approved Rosen Drawing List Number RL-00DL, shall be maintained as part of the permanent records of the modified aircraft.

If the holder agrees to permit another person to use this certificate to alter the product, the holder shall give the other person written evidence of that permission.

This certificate and the supporting data which is the basis for approval shall remain in effect until surrendered, suspended, revoked, or a termination date is otherwise established by the Administrator of the Federal Aviation Administration.

Date of application: March 1, 1986

Date reissued: March 24, 2003

Date of issuance: March 31, 1986

Date amended: March 24, 2003



By direction of the Administrator

*[Handwritten Signature]*  
\_\_\_\_\_  
(Signature)  
for Acting Manager, Seattle Aircraft Certification Office  
(Title)

Any alteration of this certificate is punishable by a fine of not exceeding \$1,000, or imprisonment not exceeding 3 years, or both.

This certificate may be transferred in accordance with FAR 21.47.



U.S. Department  
of Transportation  
**Federal Aviation  
Administration**

**Transport Airplane Directorate  
Aircraft Certification Service**

1601 Lind Avenue S.W.  
Renton, Washington 98055-4056

In Reply  
Refer To: 190S-03-200

Rosen Sunvisor Systems  
86365 College View Road  
Eugene, OR 97405

Gentlemen:

Per the transfer endorsements on the following Supplemental Type Certificates (STC), we have reissued these documents in your new name and address with a reissue date of March 24, 2003.

SA1637NM	SA3067NM	SA3650NM	SA4147NM	SR00014SE
SA2128NM	SA3068NM	SA3681NM	SA4148NM	
SA2151NM	SA3301NM	SA3687NM	SA4381NM	
SA2367NM	SA3302NM	SA3688NM	SA4391NM	
SA2383NM	SA3304NM	SA3689NM	SA4960NM	
SA2614NM	SA3305NM	SA3690NM	SA4962NM	
SA2650NM	SA3306NM	SA3691NM	SA4963NM	
SA2652NM	SA3335NM	SA3692NM	SA5136NM	
SA2672NM	SA3336NM	SA3693NM	SA5934NM	
SA2678NM	SA3342NM	SA3694NM	SH2695NM	
SA2917NM	SA3529NM	SA3695NM	SH3533NM	
SA2942NM	SA3597NM	SA3696NM	SH3817NM	
SA3066NM	SA3598NM	SA3850NM	SA00682SE	

As recipient of this approval, please review your responsibilities under the requirements of Federal Aviation Regulation (FAR) 21.3, regarding the reporting of any failure, malfunction, or defect in any article manufactured under this STC. You are required to report such occurrences except as provided in FAR 21.3(d), to the Manager, Seattle Aircraft Certification Office, at 1601 Lind Ave. SW, Renton, WA 98055-4056. The report should be communicated initially by telephone to the Manager, (425) 917-6400, within 24 hours after it has been determined that the failure has occurred. In addition, written notification to the Manager, Seattle Aircraft Certification Office, ANM-100S, at the above address is required. Federal Aviation Administration (FAA) Form 8010-4 (Malfunction or Defect Report) or any other appropriate format is acceptable in transmitting the required details.

If you plan to manufacture replacement or modification parts for sale in conformance with approved data listed on the STC, you are required to comply with FAR 21.303. A Parts Manufacturer Approval (PMA) may be issued under the provisions of FAR 21.303(d) when you submit a statement certifying you have established the fabrication inspection system as required by FAR 21.303(h). The identification requirements for parts produced under a PMA are in FAR 45.15. Your statement should be in letter form, with reference to the STC number, and should be addressed to the Federal Aviation Administration, Northwest Mountain Region, Attention: Manager, Seattle Manufacturing Inspection District Office, 2500 E. Valley Road, Suite C-2, Renton, WA 98055-4056.

You, as the STC holder, are responsible for any design changes necessary to correct unsafe conditions as well as for submitting those design changes for approval. This requirement is contained in FAR 21.99.

By acceptance of this certificate, you acknowledge that you have read and understand your responsibilities as an STC holder and are in effect certifying that you have received and hold all the available data from the previous holder.

Sincerely,

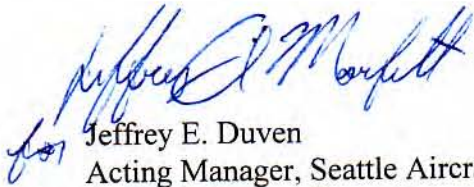
A handwritten signature in blue ink, appearing to read "Jeffrey E. Duven".

Jeffrey E. Duven  
Acting Manager, Seattle Aircraft  
Certification Office

Enclosures

# Supplemental Type Certificate

*Number* SA3343NM

*This certificate, issued to*

**Rosen Sunvisor Systems  
86365 College View Road  
Eugene, OR 97405**

*certifies that the change in the type design for the following product with the limitations and conditions therefor as specified hereon meets the airworthiness requirements of Part 25 of the Federal Aviation Regulations.*

*Original Product—Type Certificate Number:* A10CE  
*Make:* Gates Learjet Corporation  
*Model:* 27, 25, 35, and 36

*Description of the Type Design Change:* Cockpit Sun Visor installation in accordance with FAA approved Rosen Drawing List Number RL-00DL, Revision A, dated March 18, 1986, or later FAA approved revisions.

*Limitations and Conditions:* Approval of this change in type design applies basically to the above aircraft models only. This approval should not be extended to other aircraft of this model on which other previously approved modifications are incorporated unless it is determined that the interrelationship between this change and any other previously approved modifications will introduce no adverse effect upon the airworthiness of that aircraft. A copy of this certificate and FAA-approved Drawing List No. RL-00DL shall be maintained as part of the permanent records for the modified aircraft.

If the holder agrees to permit another person to use this certificate to alter the product, the holder shall give the other person written evidence of that permission.

*This certificate and the supporting data which is the basis for approval shall remain in effect until surrendered, suspended, revoked, or a termination date is otherwise established by the Administrator of the Federal Aviation Administration.*

*Date of application:* March 1, 1986  
*Date of issuance:* March 31, 1986

*Date reissued:* March 24, 2003; April 10, 2003  
*Date amended:*

*By direction of the Administrator*



*Richard J. ...*  
(Signature)  
Acting Manager, Seattle Aircraft  
Certification Office  
(Title)

Any alteration of this certificate is punishable by a fine of not exceeding \$1,000, or imprisonment not exceeding 3 years, or both.  
This certificate may be transferred in accordance with FAR 21.47.



Department of Transport

# Supplemental Type Certificate

This approval is issued to:

Rosen Sunvisor Systems  
86365 College View Road  
Eugene, Oregon  
United States of America 97405

**Number:** SA96-109

**Issue No.:** 2

**Approval Date:** 1996 October 1

**Issue Date:** 2003 October 28

<b>Responsible Office:</b>	Prairie and Northern
<b>Aircraft/Engine Type or Model:</b>	LEARJET 24, 25, 35, 36
<b>Canadian Type Certificate or Equivalent:</b>	A-128, A10CE
<b>Description of Type Design Change:</b>	Installation of Rosen Cockpit Sunvisor in accordance with FAA STC SA3343NM.

**Installation/Operating Data,  
Required Equipment and Limitations:**

Installation of the sunvisor is to be done in accordance with FAA approved Rosen Drawing List number RL-00 DL, Revision A, dated 18 March 1986, or later approved revisions.

If the holder agrees to permit another person to use this certificate to alter the product, the holder shall give the other person written evidence of that permission.

--END--



**Conditions:** This approval is only applicable to the type/model of aeronautical product specified therein. Prior to incorporating this modification, the installer shall establish that the interrelationship between this change and any other modification(s) incorporated **will not** adversely affect the airworthiness of the modified product.

D.S. Austen  
For Minister of Transport

## Installation Instructions for Lear 20-30 Series Monorail Sunvisor Systems

Kit: RL-300-1 [1584000]  
 RL-300-2 [1583000]  
 RL-300-2A [1582000]

This is a FAA STC'd Installation requiring a log book entry upon completion.

Doc: 9041-0158-003

Rev	Date	Approved
B	11/04/2008	GH

*Please read through these instructions completely before beginning.*

This installation should take approximately one hour to complete.

**Hardware:**

- |   |              |  |
|---|--------------|--|
| 2 | AN526C832R12 | #8-32 x 3/4 PHT SS B Screw                               |
| 4 | AN526C832R7  | #8-32 x 7/16 THPS SS Screw                               |
| 2 | A10K80       | #10-32 Aluminum Rivnut                                   |
| 2 | A8K75        | #8-32 Aluminum Open End Rivnut<br>(1583000,1584000 only) |
| 6 | A8K75        | #8-32 Aluminum Open End Rivnut<br>(1582000 only)         |
| 4 | 1580109      | Lear Channel Nuts (except 1582000)                       |

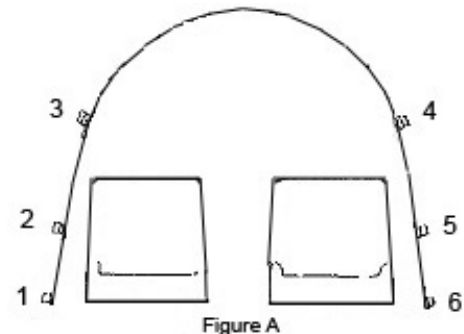

During installation of your Rosen Monorail Sunvisor System for the Lear 20-30 Series, refer to the mounting brackets by number as shown in Figure A.

These are universal instructions for the Lear 23, 24, 25, 35 and 36, but there are some differences between the individual aircraft depending upon compass location and whether they have the original Lear channel visor system. There are three possible combinations shown below:

1. No Sunvisor/Low Compass  
 Part No. 1582000 (R1582000, RL-300-2A)  
 (Most 23 and early 24.)  
 See Figure B.
2. Visor Channel Not Covered By Headliner/High Compass  
 Part No. 1583000 (R1583000, RL-300-2)  
 (Most 25 and later 24.)  
 See Figure C.
3. Sunvisor Channel Covered By Headliner/High Compass  
 Part No. 1584000 (R1584000, RL-300-1)  
 (35/36, may include later 25.)  
 See Figure D.

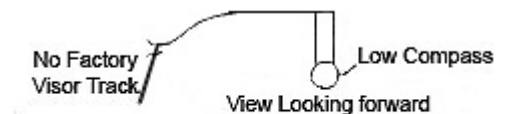

Figure B

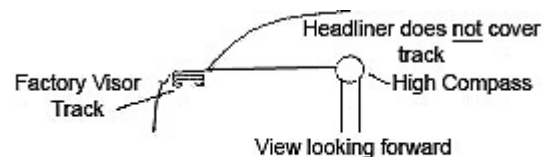

Figure C

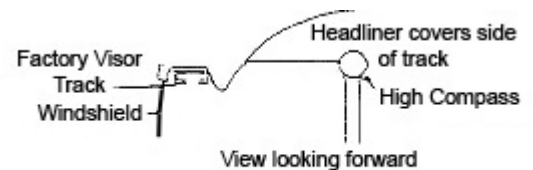

Figure D

**Lear 20 Series With Low Compass Location And No Factory Sunvisor System**

Part No. 1582000 (R1582000, RL-300-2A)

The early Lears did not have a sunvisor system so this kit was designed especially for those aircraft.

- Take the Rosen monorail into the cockpit, and with brackets underneath the lip of the headliner, move it as far forward as possible (make sure front of rail does not touch the headliner).
- With a pencil, mark the slot location of brackets 2, 3, 4, and 5. Make sure that the brackets are tight against the headliner as shown in Figure E.
- Remove rail.
- Install the A8K75 rivnut in the center of the slot marked for bracket 3 and bracket 4. This installation is in the Royalite headliner. DO NOT DRILL INTO AIRCRAFT STRUCTURE.
- Install the monorail using the AN526C832R12 fasteners provided and recheck the marks made for brackets 2 and 5.
- Remove rail and install A8K75 rivnuts for bracket locations 2 and 5.
- Reinstall rail and mark location for each end bracket 1 and 6.
- Remove rail and install A8K75 rivnuts for bracket locations 1 and 6.
- Install the A8K75 rivnuts, supplied, in the Royalite as marked.
- Reinstall the rail using the appropriate fasteners.

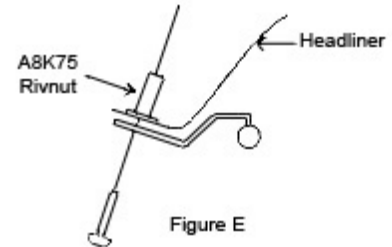

There are two A10K80 rivnuts included in the kit if it becomes necessary to relocate the fastener that holds the oxygen mask strap (some of which would be covered with the visor assembly stowed aft).

Install both visor assemblies with thumb tension knob towards pilots and install snap ring on back of screw (this will prevent over loosening).

See common operating instructions.

### **Lear 20 Series With High Compass and Factory Sunvisor System**

Part No. 1583000 (R1583000, RL-300-2)

On this unit, as well as the next, the front of the rail is bent to allow the visor assembly to move past the high compass and completely around the cockpit if desired.

- Remove the small original visors from their track but do not remove the track (i.e. channel).
- Insert two of the channel nuts, Part 1580109 (R1580109, RL200-20), into either side of the track as shown in Figure F.
- Bring the monorail system, Part 1583000 (R1583000, RL-300-2), into the cockpit and hold in place with the bottom of the brackets underneath the track of the original visor system. The brackets should align with the channel nuts which will be used to secure the rail with the exception of brackets 1 and 6 which use A8K75 rivnuts.
- Install the rail temporarily using the AN526C832R7 screws provided. Ensure that the rail is centered on the compass. The bracket will clamp onto the channel using the channel nuts on brackets 2, 3, 4, and 5.

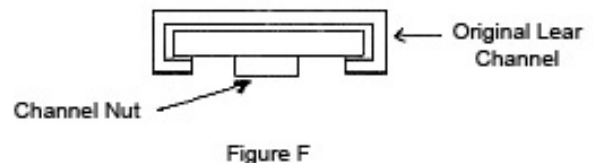

- Mark the location of the hole in brackets 1 and 6. Ensure all fasteners are snug and that there is clearance between the compass and the rail.
- Remove the rail and install the A8K75 rivnuts, supplied, in the Royalite as marked. Check the clearance where the rail passes under the compass. There should be at least .10" to allow the visor assembly to pass smoothly beneath it. If there is not sufficient clearance, brackets 3 and 4 should be shimmed slightly.
- Reinstall the rail using the appropriate fasteners (AN526C832R12 on brackets 1 and 6).

There are two A10K80 rivnuts included in the kit if it becomes necessary to relocate the fastener that holds the oxygen mask strap (some of which should be covered when the visor assembly is stowed aft).

Install both visor assemblies with the thumb tension knob towards the pilots. Install the small snap ring on back of the screw (this will prevent over loosening of the thumb tension knob).

See common operating instructions.

### **Lear 20/30 Series With High Compass Position and Factory Sunvisor System With Covered Channel**

Part No. 1584000 (R1584000, RL-300-1)

- Remove the small original visors from their track but do not remove the track (i.e. channel).
- Insert two of the channel nuts, Part No. 1580109 (R1580109, RL-200-20), into either side of the track as shown in Figure F.
- Bring the monorail system Part No. 1584000 (R1584000, RL-300-1) into the cockpit and hold in place with the bottom of the brackets underneath the track of the original visor system. The brackets should align with the channel nuts which will be used to secure the rail, with the exception of brackets 1 and 6 which will use A8K75 rivnuts.
- Install the rail temporarily using AN526832R7 screws provided. The bracket will act as a clamp on the channel using the channel nuts on brackets 2, 3, 4, and 5.
- Remove the rail and install the A8K75 rivnuts, supplied, in the Royalite as marked.
- Reinstall the rail using the appropriate fasteners (AN526C832R12 on brackets 1 and 6).
- Check the clearance where the rail passes under the compass. This should be at least .10" to allow the visor assembly to pass smoothly beneath it. If there is not sufficient clearance, brackets 3 and 4 should be shimmed slightly.
- There are two A10K80 rivnuts included in the kit if it becomes necessary to relocate the fastener that holds the oxygen mask strap (some of which would be covered with the visor when it is stowed aft).

Install both visor assemblies with the thumb tension knob towards the pilots. Install the small snap ring on back of the screw (this will prevent over loosening of the thumb tension knob).

See common operating instructions.



## Operating Instructions

To move visors, turn the thumb tension knob counterclockwise to loosen, and slide the visor along the monorail. To move beyond the mounting clips, the visor must be turned so that the slot in the clamping blocks can move past the monorail brackets. Your monorail system is equipped with a swivel action so that the visor can be rotated in the vertical axis. Rotational tension can be increased or decreased simply by turning the two socket head cap screws on the back of the clamping block assembly. Prior to moving along the track the visor should be returned to the straight fore and aft position.

In most aircraft our visors are rotated up to the overhead to stow, but due to the smallness of the Lear cockpit you will slide the visor assemblies aft to stow. There is sufficient room between the window and bulkhead to stow the visor in its down position. There are two A10K80 rivnuts included in your system kit in case of visor interference with the release strap on the oxygen mask. Since all Lear's are not identical, the rivnuts allow the operator to drop that particular fastener several inches if necessary.

As this is a one-piece monorail system, either visor can move the entire length of the rail allowing complete sun shielding previously not possible.

A retaining ring is installed on the rear of the thumb tension knob as an indicator that no more counterclockwise movement of the knob should be attempted.

## Continued Airworthiness Instructions:

- **(On the ground only)**
  - Periodically clean the lenses with a soft cloth, mild soap and water or Rosen Cleaner, Polisher and Protectant. Do not use abrasives on the lens.
  - Periodically adjust the pivot tensions on the visor assemblies.
  - Periodically clean rail with a no residue alcohol based cleaner
- Updates to this Continued Airworthiness section are available on the Rosen Website. ([www.rosenvisor.com](http://www.rosenvisor.com))

The most up to date version of this document is available on the Rosen Website. ([www.rosenvisor.com](http://www.rosenvisor.com)) We recommend that you periodically look to make sure you are using the most current version.

## Airworthiness Limitations:

The Airworthiness Limitations Section is FAA approved and specifies maintenance required under §43.16 and §91.403 of the Federal Aviation Regulations unless an alternative program has been FAA approved.

There are no airworthiness limitations associated with this installation.

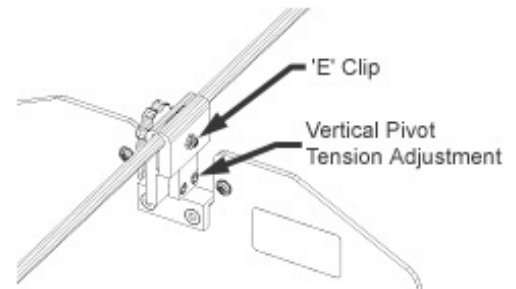
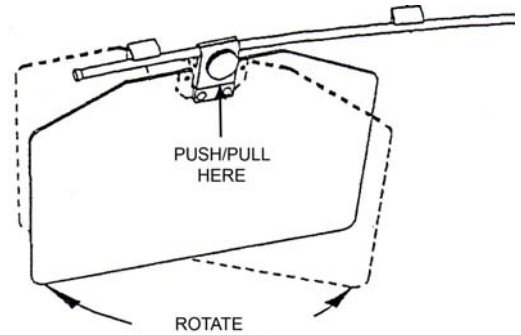



**Lear 20-30 Series Monorail Sunvisor System**

Date	Revision	Approved
2/18/22	J	SYS

Kit RL-300-1  
 Kit RL-300-2  
 Kit RL-300-2A

**Drawing List RL-00 DL**

**9040-0158-003**

R158xxxx			Drawing	Replaces	Description	Rev
2000	3000	4000				
RL-300-						
2A	2	1				
<b>1</b>			<b>1582000</b>	<b>R1582000</b> <b>RL-300-2A</b>	<b>Complete Lear 23/24 Early Monorail System</b>	<b>A</b>
1			1582100	RL24/23-200-3	Monorail Assembly	B
1			1582101	RL-100-2	Monorail	B
2			1582201	RL-100-8	Mid Bracket	A
2			1582202	RL-100-7	Front Bracket	A
2			1584201	RL-100-3	Rear Bracket	A
	<b>1</b>		<b>1583000</b>	<b>R1583000</b> <b>RL-300-2</b>	<b>Complete Lear 25/24 Late Monorail System</b>	<b>A</b>
	1		1583100	RL25/24-200-3	Monorail Assembly	B
	1		1584101	RL-100-1	Monorail	B
	2		1583201	RL-100-6	Mid Bracket	A
	2		1583202	RL-100-5	Front Bracket	A
	2		1584201	RL-100-3	Rear Bracket	A
		<b>1</b>	<b>1584000</b>	<b>R1584000</b> <b>RL-300-1</b>	<b>Complete Lear 35/36 Monorail System</b>	<b>A</b>
		1	1584100	RL35/36/200-3	Monorail Assembly	C
		1	1584101	RL-100-1	Monorail	B
		2	1584201	RL-100-3	Rear Bracket	A
		4	1584202	RL-100-4	Mid, Front Bracket	A
	4	4	1580109	R1580109 RL200-20	Lear Channel Nut	E
Continued....						

R158xxxx			Drawing	Replaces	Description	Rev
2000	3000	4000				
RL-300-						
2A	2	1				
<b>2</b>	<b>2</b>	<b>2</b>	<b>1584400</b>	<b>R1584400</b>	<b>Visor Assembly</b>	<b>A</b>
				<b>RL-300-3</b>		
2	2	2	1584401	R1584401 RL-200-1	Lens	B
2	2	2	1110202	RL-200-8AB	Swivel Nut Plate	E
2	2	2	1120000-001		Complete Assembly	K
2	2	2	1120101-001	R1120101-001 RCBS-100-7A	Nut Plate Standard	L
2	2	2	1120102-001	R11201202-001 RCBS-100-8AB	Clamping Block Body	L
2	2	2	1120203	R1120203 RCBS-300-8	Swivel	P
2	2	2	1120104	R1120104-002	Thumb Knob – Standard	M
				<b>KITS</b>		
			<b>RCBS-300-11M</b>		<b>Kit, Standard Thumb Knob</b>	<b>D</b>
			1120104-002		Thumb Knob	M
			RCBS-300-18		Spring	
			PCS-1000-14-STZ		E-Clip	
			<b>RCBS-100</b>		<b>Clamping Block Assembly</b>	<b>E</b>
			1120000-001		Clamping Block	K
			1110202		Swivel Nut Plate	E
			<b>R1584401</b>		<b>Lens</b>	<b>B</b>
1	1	1	9041-0158-003		Installation Instructions	B