

Rosen King Air NSA Sunvisor System

Installation Instructions
Drawing #RBKA-400-NSA

- These units are screw-in replacements for any older King Air with the ball joint style arm visor.
- However, rivnuts are supplied to allow them to be installed in newer King Airs that have the Beech rail system.
- In older aircraft, simply remove the original equipment and replace them with the Rosen units, installing the visors as marked for pilot and copilots side.
- If you have the royalite trim curving the mounting plate on the original equipment you may elect to remove this and install between the Rosen mounting plate and swivel.

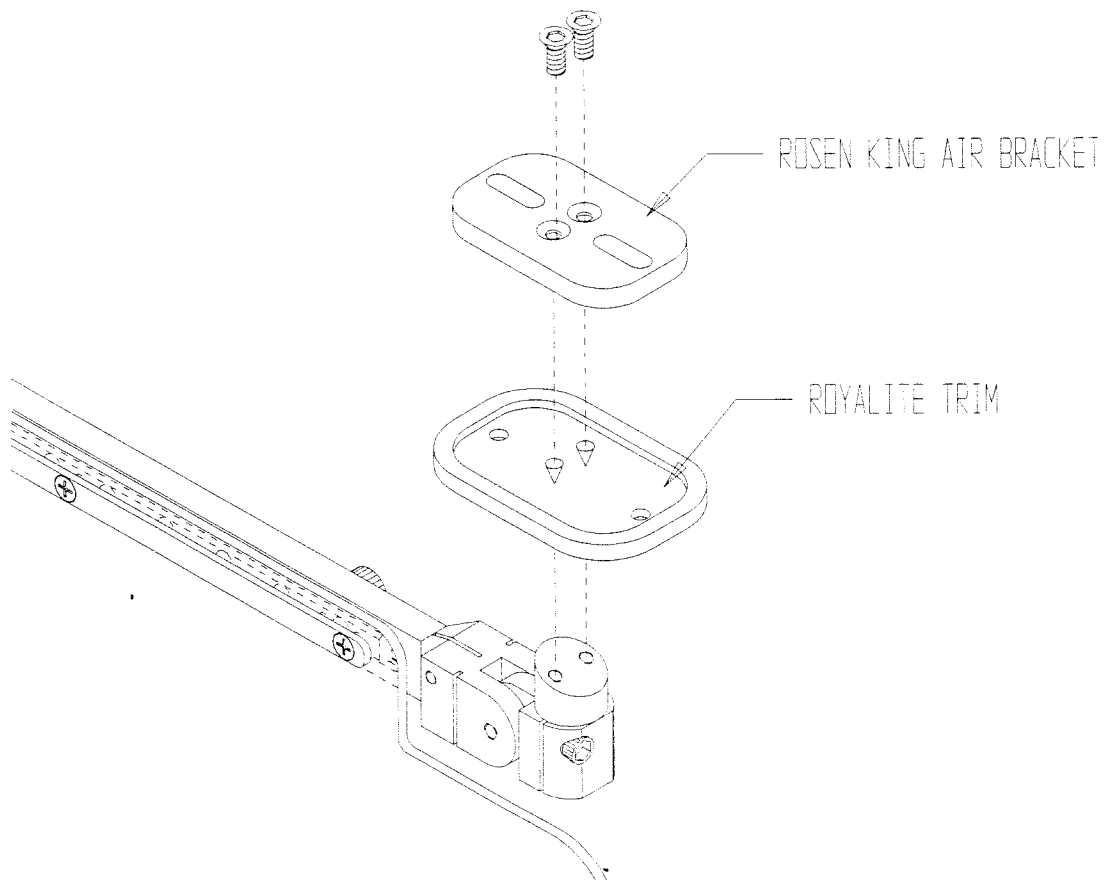

Mark the holes for the attach screws for the Rosen swivel and drill Royalite trim piece and then reinstall.

- For aircraft that use the later Beech 1/2" diameter rail, rivnuts are included.