

United States of America
Department of Transportation—Federal Aviation Administration
Supplemental Type Certificate

Number SA5983NM

This certificate, issued to **Rosen Sunvisor Systems
86365 College View Road
Eugene, OR 97405**

*certifies that the change in the type design for the following product with the limitations and conditions therefor as specified hereon meets the airworthiness requirements of Part * of the * Regulations.*

Original Product—Type Certificate Number: *See attached FAA Approved Model List (AML)
Make: No. SA5983NM for a list of approved airplane
Model: models and applicable airworthiness regulations

Description of the Type Design Change: Cockpit Sun Visor installation in accordance with FAA approved Rosen Drawing List Number RCOM-00DL, Revision A, dated June 29, 1993, or later FAA approved revisions.

Limitations and Conditions: Approval of this change in type design applies to only those Piper Aircraft Models listed on AML SA5983NM. This approval should not be extended to other aircraft of this model on which other previously approved modifications are incorporated unless it is determined that the interrelationship between this change and any other previously approved modifications, including changes in type design, will introduce no adverse effect upon the airworthiness of that aircraft. A copy of this Certificate, AML, and FAA approved Rosen Drawing List Number RCOM-00DL, Revision A, or later FAA approved revision, shall be maintained as part of the permanent records for the modified aircraft.

If the holder agrees to permit another person to use this certificate to alter the product, the holder shall give the other person written evidence of that permission.

This certificate and the supporting data which is the basis for approval shall remain in effect until surrendered, suspended, revoked, or a termination date is otherwise established by the Administrator of the Federal Aviation Administration.

Date of application: May 11, 1993

Date reissued: March 24, 2003

Date of issuance: August 23, 1993

Date amended: December 29, 1993; March 24, 2003

By direction of the Administrator



Richard J. Anderson
(Signature)

Acting Manager, Seattle Aircraft
Certification Office

(Title)

Any alteration of this certificate is punishable by a fine of not exceeding \$1,000, or imprisonment not exceeding 3 years, or both.

This certificate may be transferred in accordance with FAR 21.47.

**FAA APPROVED MODEL LIST (AML) SA5983NM
FOR
INSTALLATION OF ROSEN SUNVISOR SYSTEMS COCKPIT SUN VISOR**

ISSUE DATE: December 27, 1993

ITEM	AIRPLANE MAKE	AIRPLANE MODEL	TYPE CERTIFICATE NUMBER	CERTIFICATION BASIS FOR ALTERATION	FAA APPROVED DRAWING LIST		AML AMENDED
					NUMBER	REVISION NO. AND DATE	DATE
1.	Piper	PA-24, PA-24-180, PA-24-250, PA-24-260, PA-24-400	1A15	CAR 3	RCOM-00DL, Revision A	6/29/93	3/24/03
2.	Piper	PA-30, PA-39, PA-40	A1EA	CAR 3	RCOM-00DL, Revision A	6/29/93	3/24/03

FAA APPROVED:

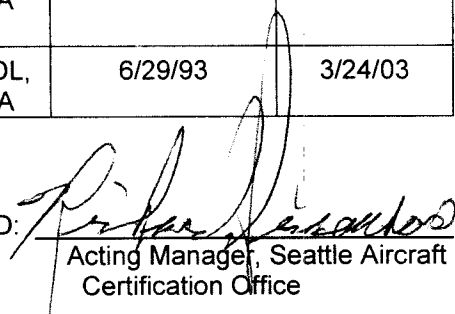

Acting Manager, Seattle Aircraft
Certification Office

REISSUED: March 24, 2003

AMENDED: March 24, 2003



Piper Comanche
NSA Sunvisor System

Date	Revision	Aprv
2/14/22	K	SYS

Drawing List
RCOM-00 DL

Doc # 9050-0121-001

Comanche			Drawing #'s	Reference (Replaces)	Description	Rev.
300-1	300-1A	1210003				
*			1210001	RCOM-300-1	Complete System NSA	E
	*		1210002	RCOM-300-1A	Complete System 3 rd Axis	F
		*	1210003		Piper - Knots2U (Arapaho) 3 rd Axis	B
		2	1160101-1		Mounting Plate	F
		2	1160102-1		Bonanza Style Swivel	H
2	2	2	1010000-5		NSA Slide Assembly	F
2	2	2	1010001-5	RNSA-100-6, -7	Female Slide	M
2	2	2	1010002-3	RNSA-100-4, -5	Male Slide	T
2	2	2	1010003	RCOM-200-4	Lens Strip	G
2			1020001	R1020001 RNSA-100-1	Original Block	P
	2	2	1020100-001		Mod Block Assembly	F
	2	2	1020002-001	RNSA-300-2	Mod Block A	P
	2	2	1020003-001	RNSA-300-3	Mod Block B	V
2	2		1210101-001, -002	RCOM-200-6, -6A	Piper Comanche Bracket	E
2	2		1210102	RCOM-200-8	Swivel	D
2	2	2	1210201	RCOM-200-1	Comanche NSA Lens	H
1	1		9051-0121-001	RCOM-400	Piper Comanche NSA System CMM/ICA/IPC	C



			R1010000-KIT-5	Kits		
1	1	1	1010000-5		Universal Slide with Lens Strip Kit Complete Slide Assembly	A
1	1	1	1010003		Lens Strip	F
3	3	3	MS24693-C48BP		#8-32 X .375 Flat Head Phillips SS Black Patch Screw	G
		1	R1160102-1 1160102-1		Bonanza Style Swivel Kit Bonanza Style Swivel Magnalube	H
			R1210201		Lens Kit	H

**Rosen Sunvisor Systems CMM / IPC for Sunvisor Assembly
(P/N R1210001, R1210002, R1210003)**



Piper Comanche NSA Sunvisor System

Rosen Kit Number R1210001, R1210002, R1210003

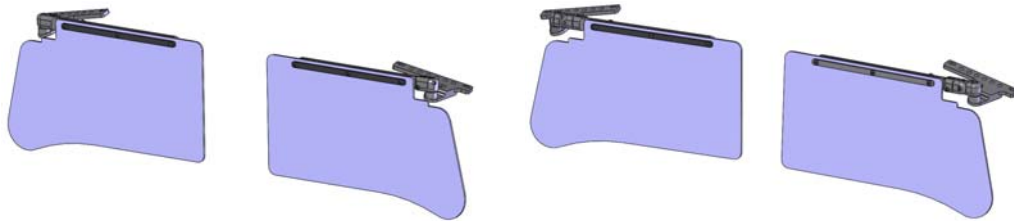

R1210001

R1210002

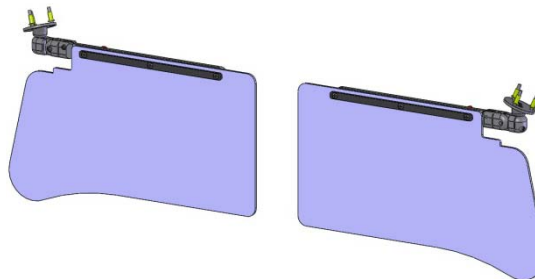

R1210003

**Component Maintenance Manual
with Illustrated Parts List
and Instructions for Continued Airworthiness**

**Manual Number
Rosen 9051-0121-001
Revision C**

August 04, 2015

Rosen Sunvisor Systems LLC
86365 College View Road
Eugene, Oregon 97405 USA

**Rosen Sunvisor Systems CMM / IPC for Sunvisor Assembly
(P/N R1210001, R1210002, R1210003)**

This ICA must be followed when the R1210001, R1210002 or R1210003 Sunvisor systems are installed in accordance with Supplemental Type Certificate, (STC) No. SA5983NM, dated March 24, 2003.

The information contained in this document supplements or supersedes the basic manual only in those areas listed herein. For limitations, procedures, and performance information not contained in this manual, consult the basic aircraft ICA or Maintenance Manual.

STATEMENT OF Rev C CERTIFICATION

This manual complies with Federal Aviation Association (FAA) Airworthiness Requirements Part 23.

FAA Acceptance: Thane Rockhill (MKC-AEG) Date: 3/31/16

The above certification does not apply to revisions or amendments made after the date of initial certification by other Approved Organizations. Revisions or amendments made by other Approved Organizations must be separately certified and recorded on separate record sheets

**Rosen Sunvisor Systems CMM / IPC for Sunvisor Assembly
(P/N R1210001, R1210002, R1210003)**

Record of Revisions

Rev	Description	Date	Approved
C	Update to CMM/IPC format. Combine installation instructions 9051-0121-001 and 9051-0121-002.	6/11/15	GH

Table of Contents

Record of Revisions	3
Introduction	4
General	4
Revision Service	4
Fault Isolation	5
Product Description	6
Installation Instructions	6
Removal	9
Weight and Balance	10
Repair	10
Instructions for Continued Airworthiness	10
Airworthiness Limitations	10
System Images	11-15
Parts List	16

**Rosen Sunvisor Systems CMM / IPC for Sunvisor Assembly
(P/N R1210001, R1210002, R1210003)**

Introduction

1. General

- a. This Rosen Component Maintenance Manual provides use, maintenance and supplemental airworthiness instructions for the cockpit Sunvisor system used on the Piper PA-24, PA-24-180, PA-24-250, PA-24-260, PA-24-400, PA-30, PA-39, and PA-40 model series aircraft. See FAA Approved Model List (AML) SA5983NM.
- b. Rosen reserves the right to revise this document for changed procedures, improved parts or changes to the system or components.
- c. All technical support, spare sales, repairs or modifications are to be directed directly to Rosen Sunvisor Systems LLC. RSS must be contacted for future revision of this document as it is possible this does not contain the latest revisions.

2. Revision Service

Current revision status and revisions to this document may be obtained from Rosen Sunvisor Systems' website: www.rosenvisor.com. We recommend that you periodically check to make sure you are using the most current version.

**Rosen Sunvisor Systems CMM / IPC for Sunvisor Assembly
(P/N R1210001, R1210002, R1210003)**

Fault Isolation

1. General

- a. This section identifies Probable Causes and Corrections for possible faults.

Problem	Probable Cause	Corrective Action
Visor does not extend on arm	Tension Thumb knob too tight	Loosen knob and slide using knob
Lens does not rotate smoothly on vertical axis	Vertical pivot tension incorrectly set	Re-tension vertical pivot
Lens does not rotate smoothly on horizontal axis	Horizontal pivot tension incorrectly set	Re-tension horizontal pivot

**Rosen Sunvisor Systems CMM / IPC for Sunvisor Assembly
(P/N R1210001, R1210002, R1210003)**

Product Description

General

- a. The Rosen Sunvisor System consists of two visor assemblies which have been designed to improve pilot comfort during standard cockpit operations. The visor assemblies are fastened to the airframe in the same mounting positions as the factory installed visors.

**Installation Instructions for Piper Comanche
(Kit R1210001, R1210002)**

This is an FAA STC'd Installation requiring a log book entry upon completion.

Pease read through these instructions completely before beginning.

Hardware:

4	MS16995-20B	#6-32 X ¾ Socket Head Cap Screw
8	AN960-C6L	#6 Aluminum Washers
1	5/32 Hex Key	
1	7/64 Hex Key	
1	9/64 Hex Key	

NOTE: These instructions cover both the standard Rosen Sunvisor for the Comanche (Kit RCOM-300-1) and the Comanche Third Axis Unit (Kit RCOM-300-1A)

- The common factor in the Comanche is the upper front windscreen trim and the #6-32 screws that hold it in place.
- First remove your present Sunvisor and replace the screw in the inboard hole leaving the outboard hole exposed.
- Remove the outermost #6-32 fasteners from the trim piece on both the pilot and co-pilot side.
- Install the pilot mounting bracket and slide assembly using the provided stainless steel #6-32 X ¾ inch socket head cap screws with washers on both sides of the mounting bracket as shown. A 7/64 Allen key is provided to ensure a snug fit.

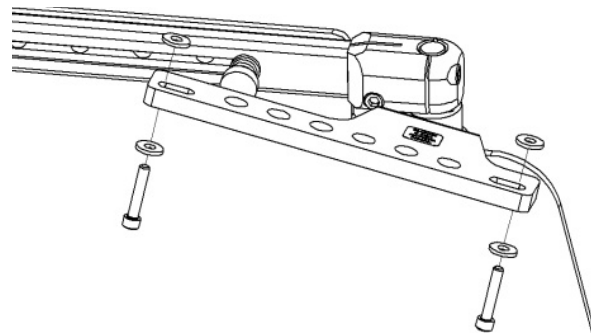

**Rosen Sunvisor Systems CMM / IPC for Sunvisor Assembly
(P/N R1210001, R1210002, R1210003)**

- To be sure you are mounting the units on the correct side the brackets as viewed from above should look as follows.

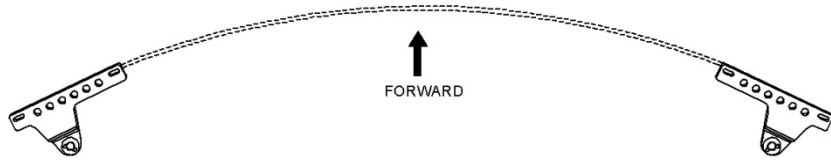

- And as seen from the seats looking forward:



- Repeat procedure for the co-pilot side.
- To operate simply tension the visor movement to your desired tension with the Allen keys provided.

- Motion to the side window is controlled with the cap screw in the back of the block.
- Motion to rotate the visor to the overhead is controlled by the socket head cap screw in the side of the block.
- Third axis tension, if equipped, is controlled by the #10-32 socket head cap screw as shown.

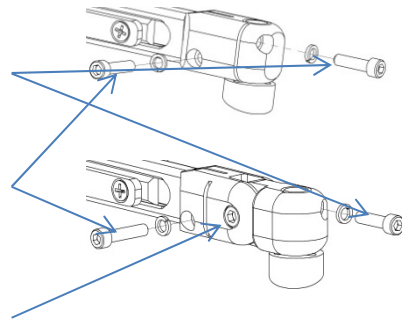

- The visors will extend in the slides and should move far enough to the rear to cover the entire face. Tension can be adjusted with the red thumb knob.

Note: The red knob will be towards the windscreen.

- Your visors can be stowed overhead in several different positions as indicated right.
- Because of different pilot heights and seat positions the stowage position will be different for different pilots. On the co-pilot side a forward stowage position is recommended to keep clear of the doorway when open.

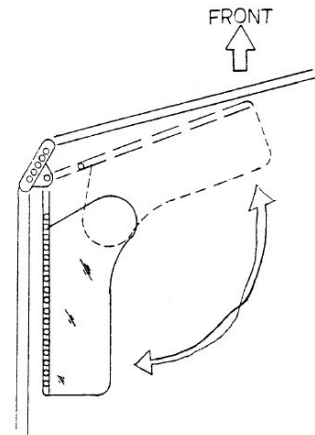

**Rosen Sunvisor Systems CMM / IPC for Sunvisor Assembly
(P/N R1210001, R1210002, R1210003)**

**Installation Instructions for Piper Comanche
with Knots2U Arapaho Windshield (Kit R1210003)**

This is an FAA STC'd installation requiring a log book entry upon completion.

Please read through these instructions completely before beginning.

Hardware:

- 6 MS24693-C48BP #8-32 X .375 Phillips Flat Head Screw 100
(Black/Patch)
- 6 A8K75 #8-32 Rivnut
- 1 5/32 Hex Key
- 1 7/64 Hex Key
- 1 9/64 Hex Key

These instructions cover the installation for a Piper PA30, PA39, and PA40 with the Knots2U Arapaho windshield configuration. The longer Arapaho windshield eliminates the mounting position over the windshield.

- If there are existing visors, remove them.
- On the pilot side remove enough of the interior linings to gain access to the aircraft interior metal structure in the upper corner where the side window meets the front window.
- Do the same on the copilot side where the door jam is.
- On each side, position the round mount against the structure and orient it so the post is as vertical as possible. Both sides should be at the same height in the aircraft.
- Mark the three mounting holes on each side.
- Drill all marked locations to .221/.226 diameter.
Note: Drill only through interior sheet metal. Maximum depth must not exceed 1/4 inch. It is the installer's responsibility to assure that there are no wires or controls damaged in this operation.
- Use a small rat tail file to put a 1/32" notch in each hole for the key in the rivnut.
- Install the rivnut using appropriate tooling.



**Rosen Sunvisor Systems CMM / IPC for Sunvisor Assembly
(P/N R1210001, R1210002, R1210003)**

- Trim and or return the interior linings into position. (If necessary cut a hole for each mounting screw.)
- Install and tighten each mount in location with the swivel post pointing down.
- Apply a small amount of lube to the full diameter of the swivel post.
- Mount the visor assembly on each side and secure with a 8-32 X .625 cap screw and #8 high collar washer. Note: The red knob is closest to the windscreen.

Note: The 8-32 mounting screw is offset and must align with the recess in the swivel.

- Using the hex keys, adjust the tensions so the motion is smooth but tight.

- Motion to the side window is controlled with the cap screw in the back of the block.
- Motion to rotate the visor to the overhead is controlled by the socket head cap screw in the side of the block.
- Third axis tension, if equipped, is controlled by the #10-32 socket head cap screw as shown.

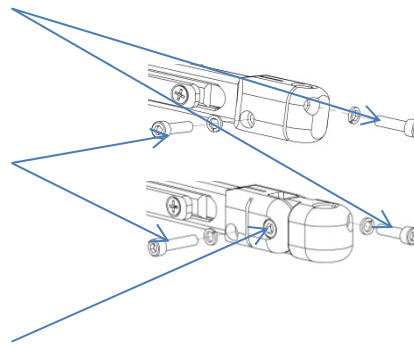

- The visors will extend in the slides and should move far enough to the rear to cover the entire face. Tension can be adjusted with the red thumb knob.

Note: The red knob will be towards the windscreen.

- Your visors can be stowed overhead in several different positions as indicated right.
- Because of different pilot heights and seat positions the stowage position will vary for different pilots. On the copilot side a forward stowage position is recommended to keep clear of the doorway when open.

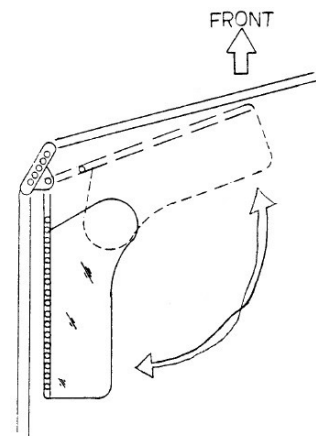

Removal

- a. Reverse installation procedure.

**Rosen Sunvisor Systems CMM / IPC for Sunvisor Assembly
(P/N R1210001, R1210002, R1210003)**

Weight and Balance

Because operators calculate Weight and Balance differently the actual station number must be determined by the installer's calculations.

With the visor located in forward use position, the R1210001 system adds 1.13 lbs., the R1210002 system adds 1.19 lbs., and the R1210003 system adds 2.08 lbs. located at the mount point of the visor. When the original visors are removed they must be weighed and removed from the calculation.

Repair

General

- a. All components that do not meet the requirements for continued use must be replaced.

Instructions for Continued Airworthiness

- **(On the ground only)**
 - Periodically clean the lenses with a soft cloth, mild soap and water or Rosen Cleaner, Polisher and Protectant. Do not use abrasives on the lens.
 - Periodically adjust the pivot tensions on the visor assemblies.

Airworthiness Limitations

The Airworthiness Limitations Section is FAA approved and specifies maintenance required under §43.16 and §91.403 of the Federal Aviation Regulations unless an alternative program has been FAA approved.

There are no airworthiness limitations associated with this installation.

Rosen Sunvisor Systems CMM / IPC for Sunvisor Assembly
(P/N R1210001, R1210002, R1210003)

Illustrations and IPC

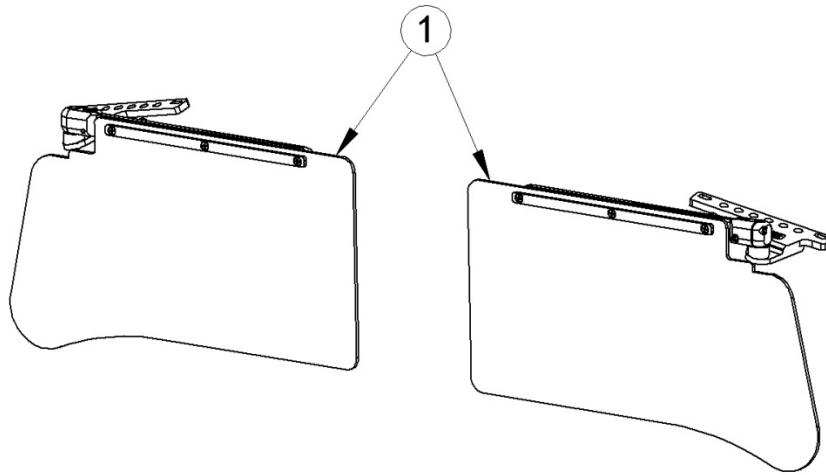

Fig 1

1210001

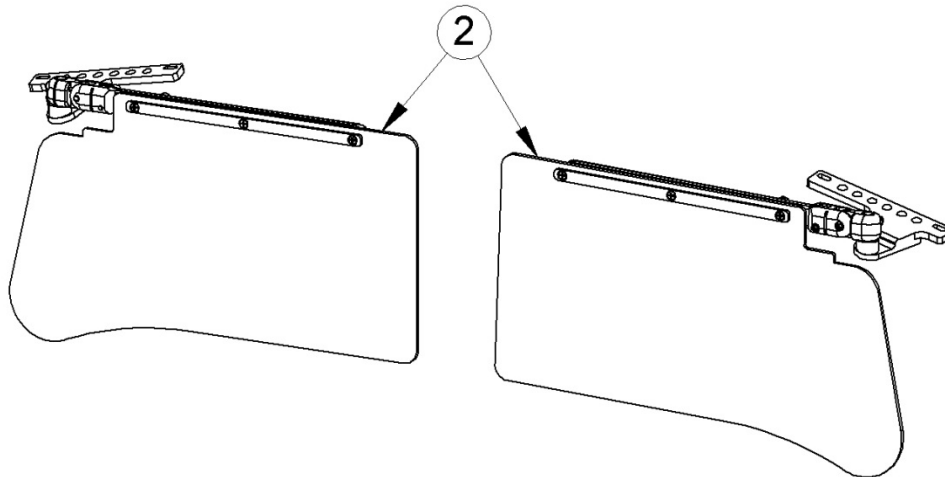

Fig 2

1210002

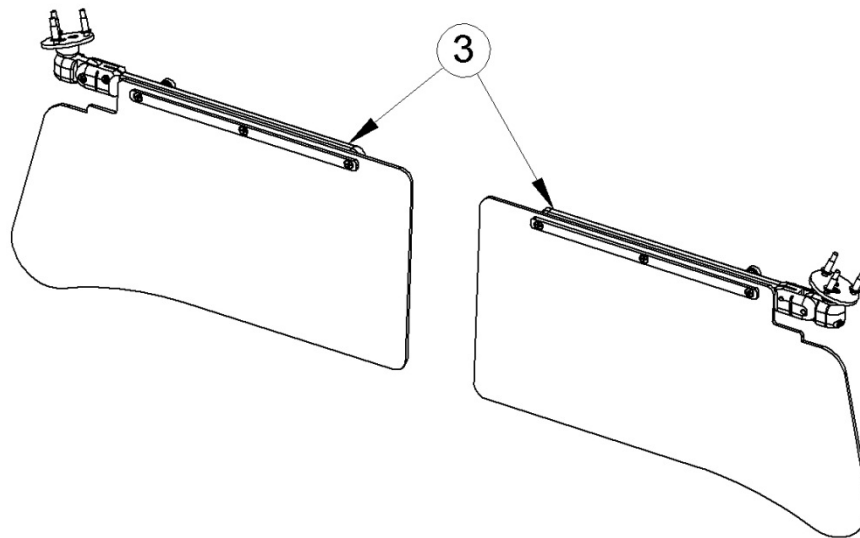

Fig 3

1210003

Rosen Sunvisor Systems CMM / IPC for Sunvisor Assembly
(P/N R1210001, R1210002, R1210003)

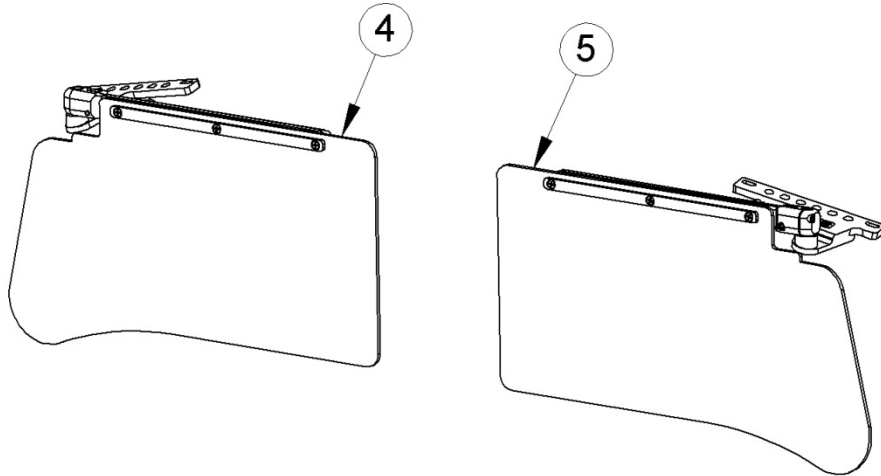

Fig 4

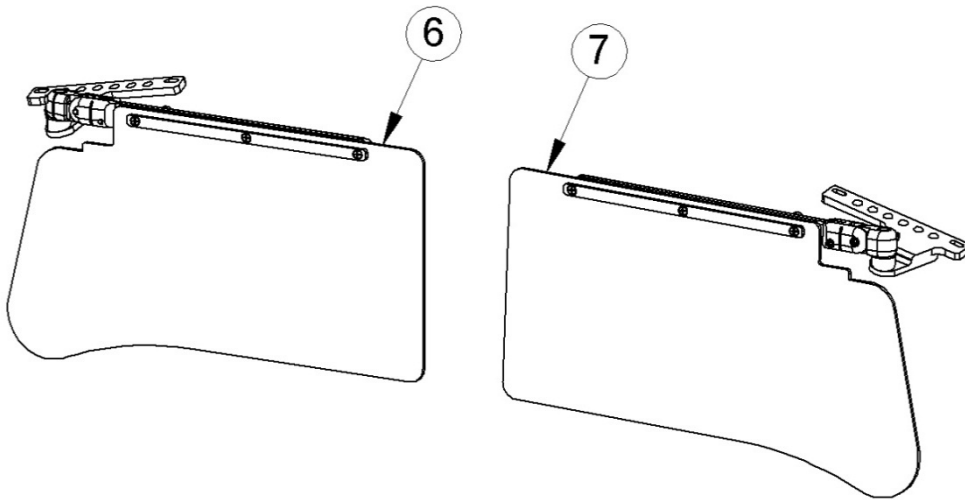

Fig 5

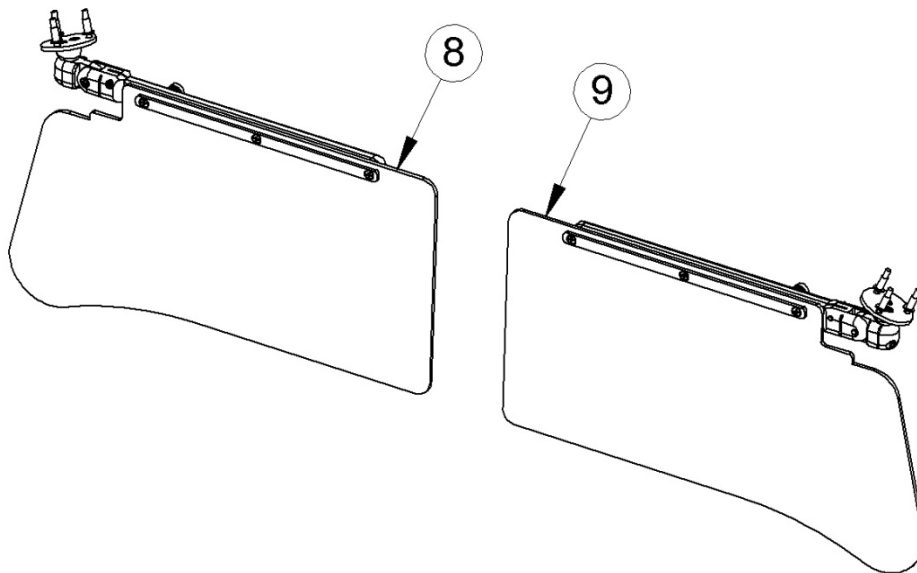

Fig 6

**Rosen Sunvisor Systems CMM / IPC for Sunvisor Assembly
(P/N R1210001, R1210002, R1210003)**

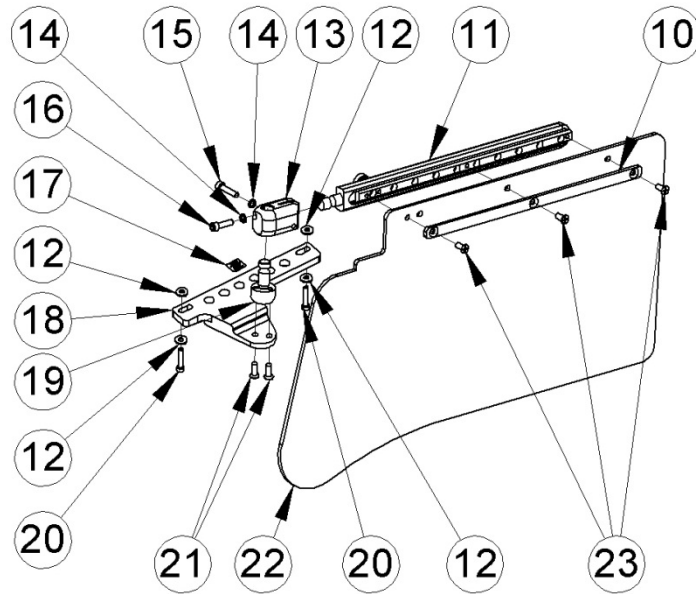

Fig 7

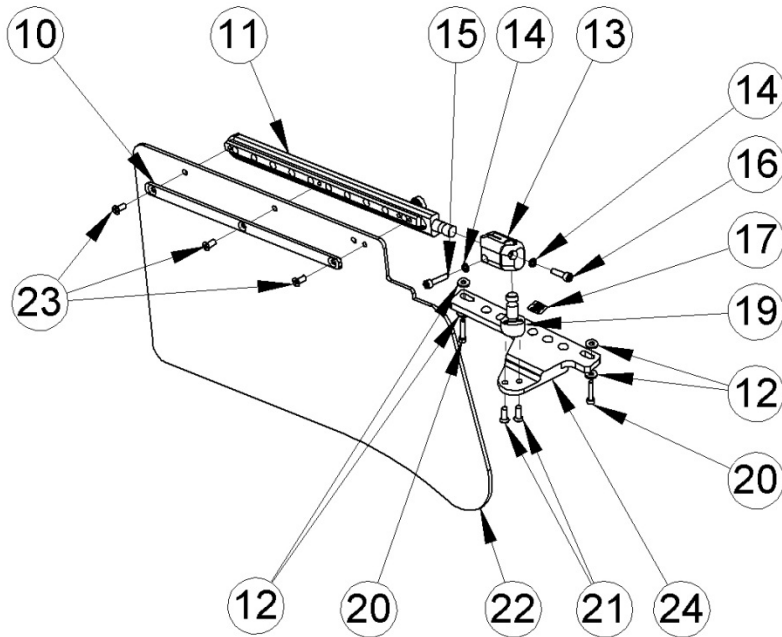

Fig 8

**Rosen Sunvisor Systems CMM / IPC for Sunvisor Assembly
(P/N R1210001, R1210002, R1210003)**

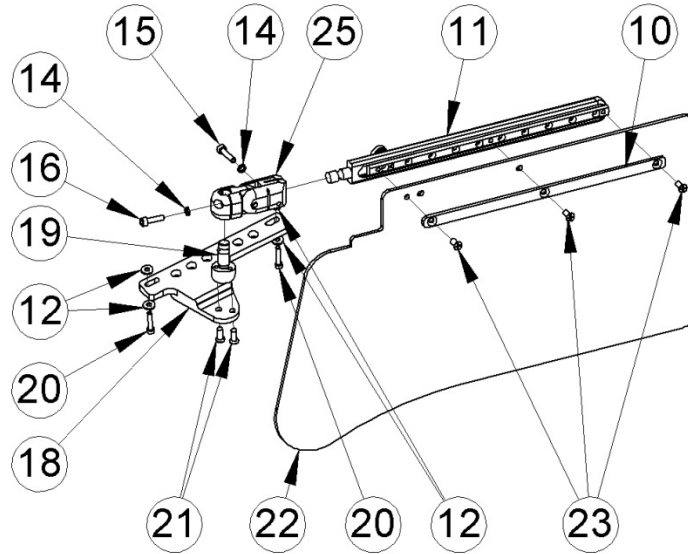

Fig 9

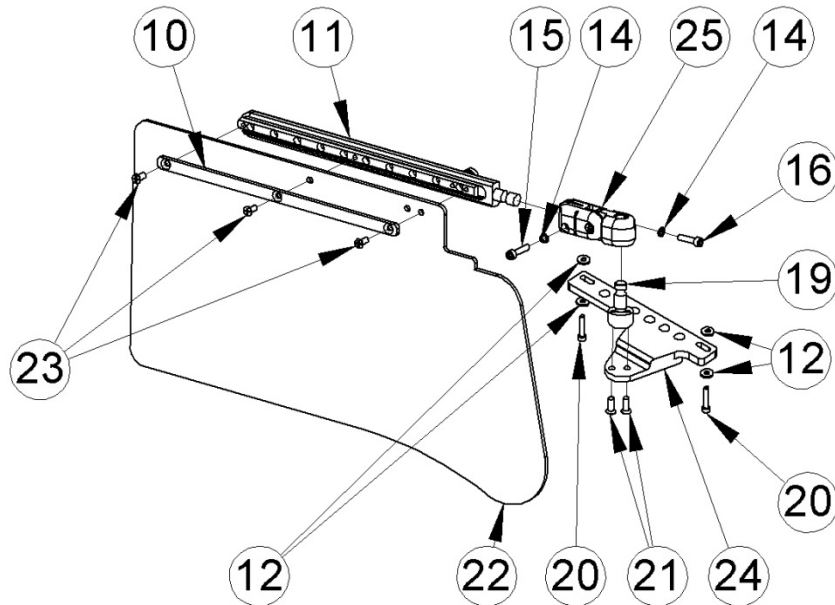

Fig 10

**Rosen Sunvisor Systems CMM / IPC for Sunvisor Assembly
(P/N R1210001, R1210002, R1210003)**

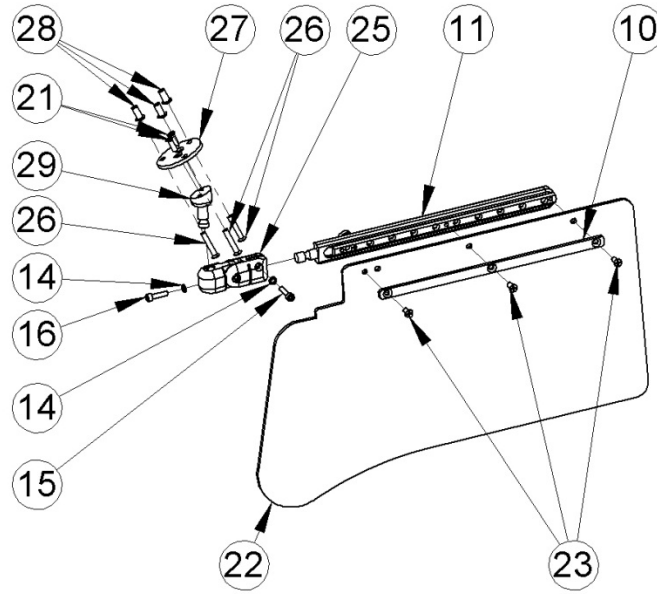

Fig 11

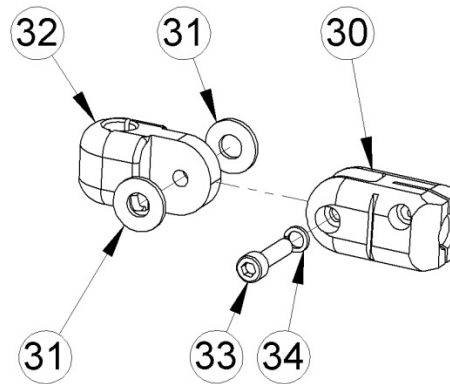

Fig 12

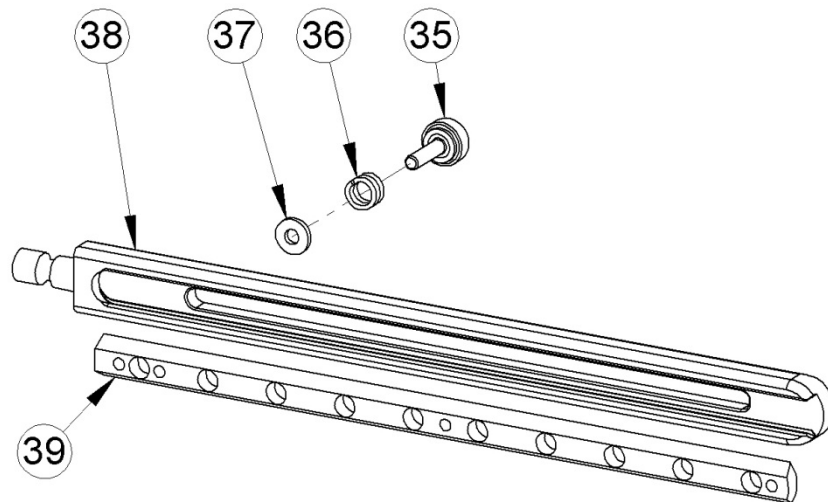

Fig 13

**Rosen Sunvisor Systems CMM / IPC for Sunvisor Assembly
(P/N R1210001, R1210002, R1210003)**

Part List

Fig. No	Fig. Item	Part Number	Description	Reference	Eff	QTY
1	1	R1210001-0	Complete System	RCOM-300-1		System
2	2	R1210002-0	Complete System 3 rd Axis	RCOM-300-1A		System
3	3	R1210003-0	Complete System Knots 2U (Arapaho) 3 rd Axis			System
4	4	R1210001-1	Pilot Side	RCOM-300-1P		1
4	5	R1210001-2	Copilot Side	RCOM-300-1C		1
5	6	R1210002-1	Pilot Side	RCOM-300-1AP		1
5	7	R1210002-2	Copilot Side	RCOM-300-1AC		1
6	8	R1210003-1	Pilot Side			1
6	9	R1210003-2	Copilot Side			1
7-11	10	1010003	Lens Strip			2
7-11	11	1010000-5	Slide Assembly			2
7-10	12	AN960-C6L	Washer #6 Flt			8
7,8	13	1020001	Original Block			2
7-11	14	8HCLW	Washer #8 High Collar Lock			4
7-11	15	MS16995-28B	Scr #8-32 X .75 Hex Socket Head Cap SST Black			2
7-11	16	MS16995-27B	Scr #8-32 X .625 Hex Socket Head Cap SST Black			2
7, 8	17	2407-1041	Label			2
7, 9	18	1210101-001	Mounting Bracket, Pilot			2
7-10	19	1210102	Swivel			2
7-10	20	MS16995-20B	Scr #6-32 X .75 Socket Head Cap			4
7-11	21	MS24693-C50B	Scr #8-32 X .50 Phillips Flt Hd Screw 100 (Black)			4
7-11	22	1210201	Lens			2
7-11	23	MS24693-C48BP	Scr #8-32 X .375 Flt Hd Phil 100 SST Black Patch			6
8,10	24	1210101-002	Mounting Bracket, Copilot			2
9-11	25	1020100-001	Mod Block Assembly			2
11	26	MS24693-C54B	Scr #8-32 X 1.00 Flt Hd Phil 100 Blk Patch			6
11	27	1160101-1	Mounting Plate			2
11	28	A8K75	#8-32 Rivnut Grip .10-.075			6

**Rosen Sunvisor Systems CMM / IPC for Sunvisor Assembly
(P/N R1210001, R1210002, R1210003)**

11	29	1160102-1	Swivel			2
12	30	1020003-001	Modified Block "A"			2
12	31	2801-0010	Washer Flt (Seastrom 5710-61-30) SST			8
12	32	1020003-001	Modified "B" Block			2
12	33	MS16996-12B	Scr #10-32 X .75 Socket Head Cap			2
12	34	10HCLW	Washer #10 High Collar Lock			2
13	35	99-701	Knob dia ½ Knurled Red #8-32 X .75			2
13	36	B-19679	Compression Spring			2
13	37	90295A110	Washer .06 X .405 OD - .175 ID Nylon			2
13	38	1010001-5	Female Slide - Universal			2
13	39	1010002-3	Male Slide – Universal			2